

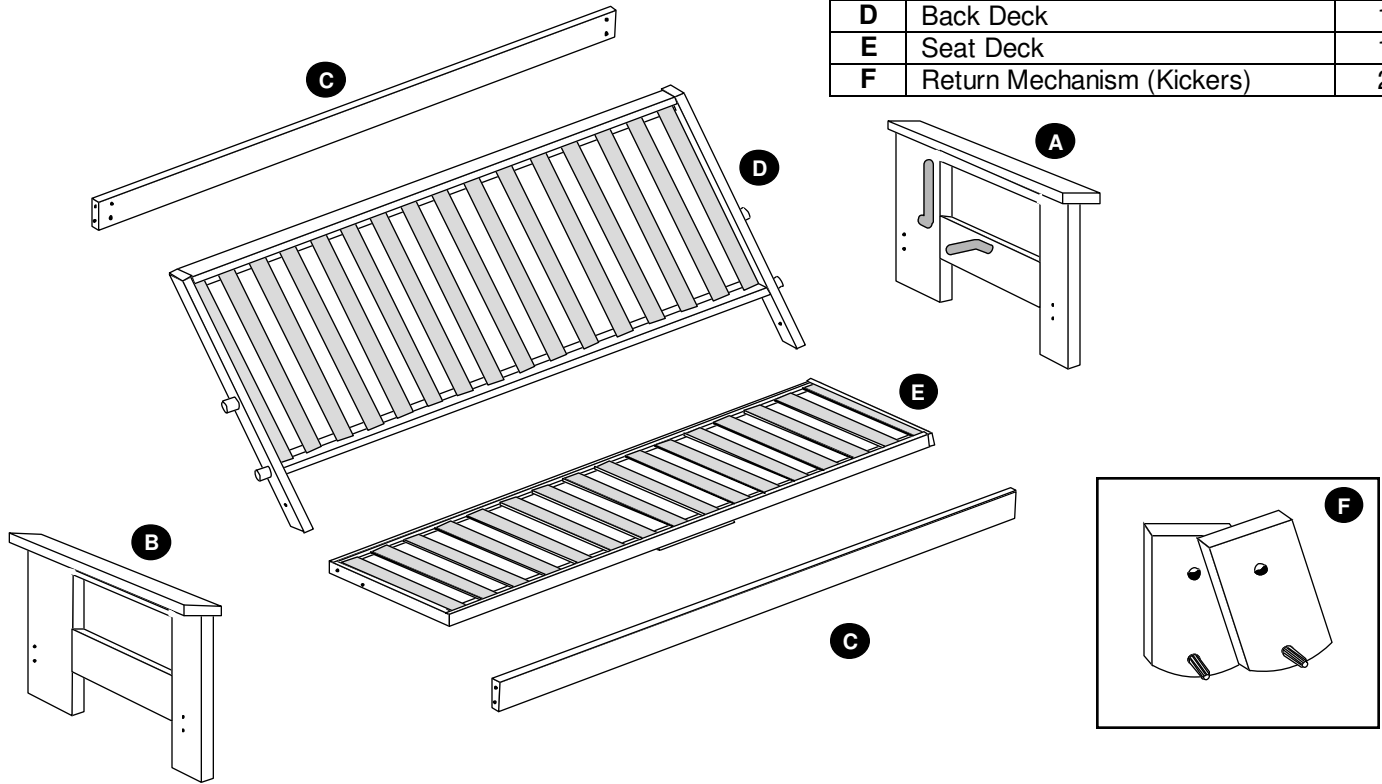



# Pine Futon Assembly Instructions



| PARTS LIST |                            |      |
|------------|----------------------------|------|
|            | DESCRIPTION                | QTY. |
| <b>A</b>   | Right Arm                  | 1    |
| <b>B</b>   | Left Arm                   | 1    |
| <b>C</b>   | Cross Rails                | 2    |
| <b>D</b>   | Back Deck                  | 1    |
| <b>E</b>   | Seat Deck                  | 1    |
| <b>F</b>   | Return Mechanism (Kickers) | 2    |

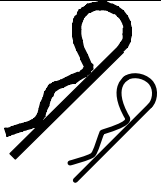
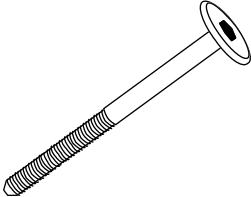
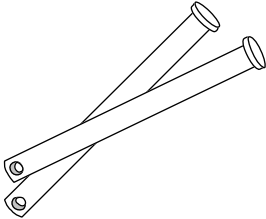
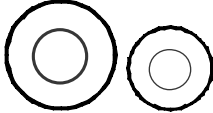

## Hardware List

| QTY. | DESCRIPTION     |   | QTY | DESCRIPTION        |   |
|------|-----------------|---|-----|--------------------|---|
| 8    | BARREL NUTS     |  | 2   | SMALL HAIR PINS    |  |
|      |                 |   | 2   | LARGE HAIR PINS    |   |
| 8    | 3 1/2" BOLTS    |  | 2   | 3 1/4" CLEVIS PINS |  |
|      |                 |   | 2   | 2 3/4" CLEVIS PINS |   |
| 6    | WASHERS (BIG)   |  | 2   | PLASTIC STOPS      |  |
| 4    | WASHERS (SMALL) |   | 4   | 5/8" SCREW         |  |

# Pine Futon Assembly Instructions

---

## READ ALL INSTRUCTIONS BEFORE ASSEMBLING!

### Step 1:

Insert barrel nuts into holes in cross rails (see *diagram 1*).

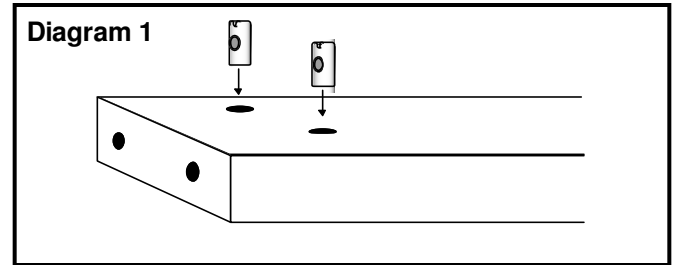

### Step 2:

Attach one cross rail to front post on each arm. Make sure the arms are positioned so that the angled slots are facing inward (see *diagram 2*). Position the cross rails so that all visible holes are facing inward and the rounded edges are up. Insert the 3 1/2" bolt through the front arm posts and into the holes in the end of the cross rails (see *diagram 2*). Thread bolts through the barrel nuts in the cross rails. **DO NOT TIGHTEN!** Repeat this process on the back cross rail on both ends.

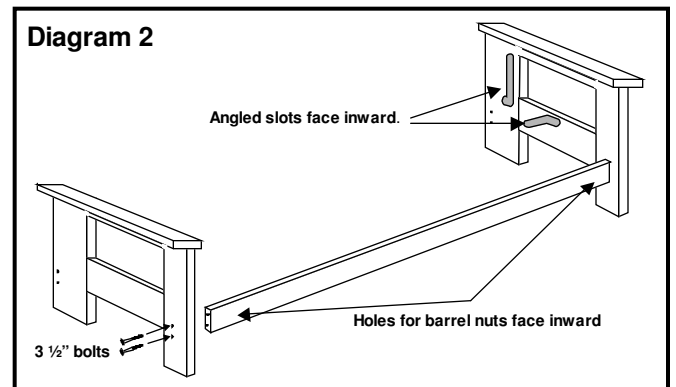

### Step 3:

Set the back deck between the arms with the slats facing up or towards the front. Install back deck by inserting the hardwood pegs into the angled slots of both arms (see *diagram 3*). Once this has been completed, all eight bolts should be tightened tight.

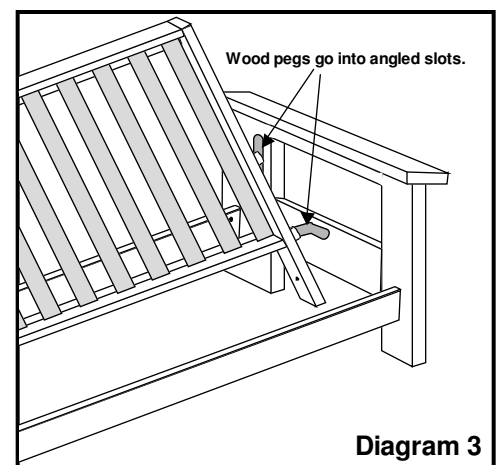

# Pine Futon Assembly Instructions

## Step 4:

Position the seat deck between the arms with the slats facing upward. Align the holes at the end of the back section with the holes on the end of the seat section. Insert the larger clevis pin from the outside. Place a small washer on the end of the clevis pin and place a big hairpin through the hole at the end of the clevis pin (see *diagram 4*).

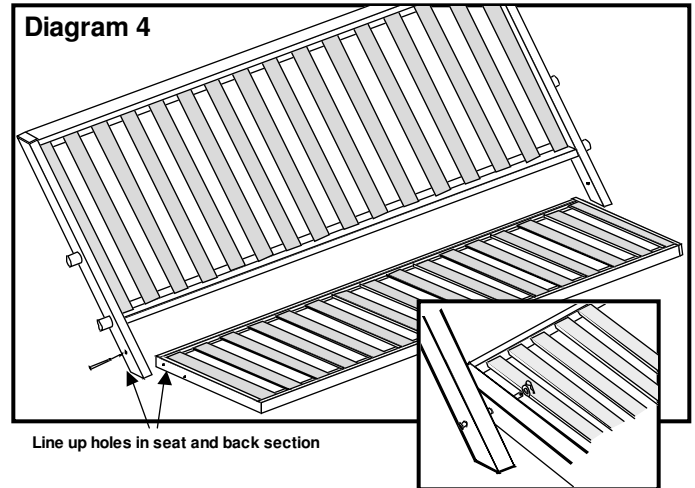

## Step 5:

Take a smaller ( $2\frac{3}{4}$ " ) clevis pin and thread it through the return mechanism with big washers on both sides. Then install it in the remaining hole on the seat section. Place another big washer on the end of the clevis pin before placing the hairpin on the end (see *diagram 5*). Make sure the wood dowel is pointing towards the futon. Do this on both sides. These blocks will make your frame front-operated.

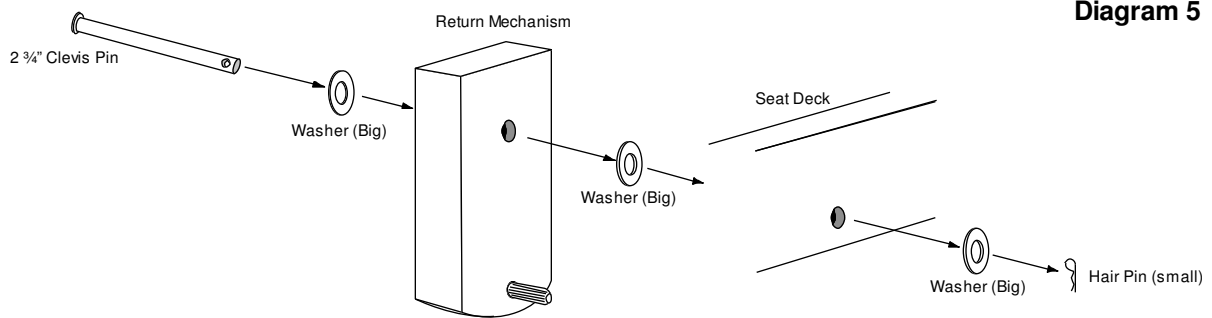

## Step 6:

Stops are used on futon frames that have oversized (innersprings or 10") futon pads that tend to push the frame open. If you have purchased a full, loveseat, or chair size futon, attach the stops on the seat section  $2\frac{1}{2}$ " from the front edge on each side (see *diagram 6*). If you have purchased a queen size futon, attach the stops  $5\frac{1}{2}$ " from the front edge of the seat section.

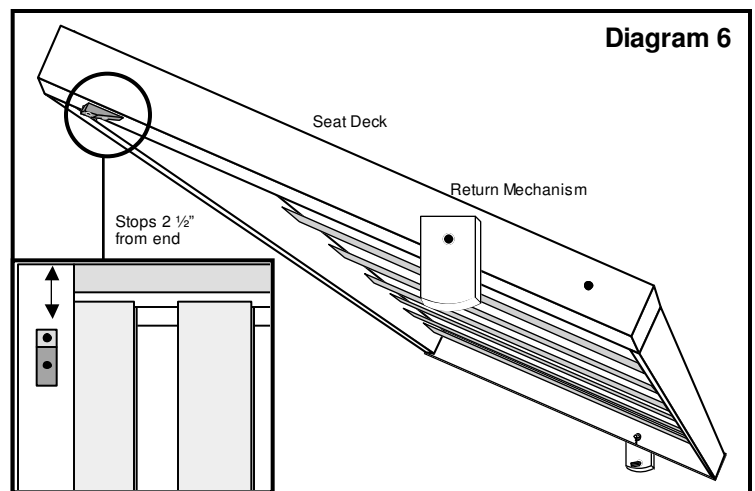

You have purchased the best built pine bi-fold couch on the market. To ensure a long life, the angle slots in the arms should be lubricated periodically with bath soap or bees wax. Touch up nicks or scratches with scratch guard.